

4

3

2

1

BOILER DATA

OPERATING VOLUME (USG)	860
OPERATING WEIGHT (LBS)	16500
HEAT INPUT (MBH)	3680
OUTPUT (HP)	90

VENT FLANGE DIMENSIONS

OD	20-1/8
ID	16
B.C.D.	2918.5
NO. OF HOLES	8
HOLE DIAMETER	1/2

CONNECTION SCHEDULE

TAG	DESCRIPTION	CONNECTION		
		SIZE (INCH)	TYPE	RATING
A*	CONTROLS	1-1/4	HALF COUPLING	3000#
B	STEAM OUTLETS	8	SORF FLANGE	150#
C*	SURFACE BLOWDOWN	3	FULL COUPLING	3000#
D	MANHOLE	12X16	ELLIPTICAL	
E	SAFETY RELIEF VALVE	3	FULL COUPLING	3000#
F*	REVERSING CHAMBER WASHOUT	3	FULL COUPLING	3000#
G*	CONDENSATE INLET	3	SORF FLANGE	150#
H	WASHOUTS	3	FULL COUPLING	3000#
J	REAR DOOR	16		
K*	LOW FIRE HOLD	1/2	FULL COUPLING	3000#
L*	FURNACE INSPECTION	3	FULL COUPLING	3000#
M	TUBE PULL	155		

* - Owner chooses left/right installation

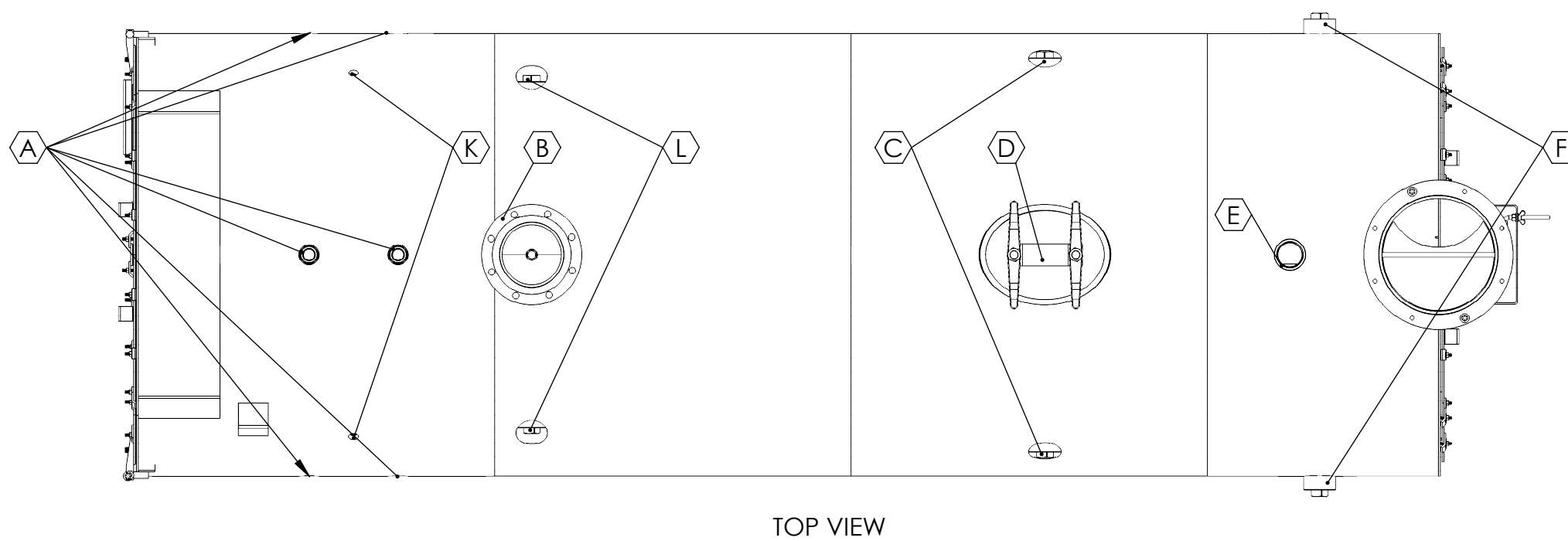
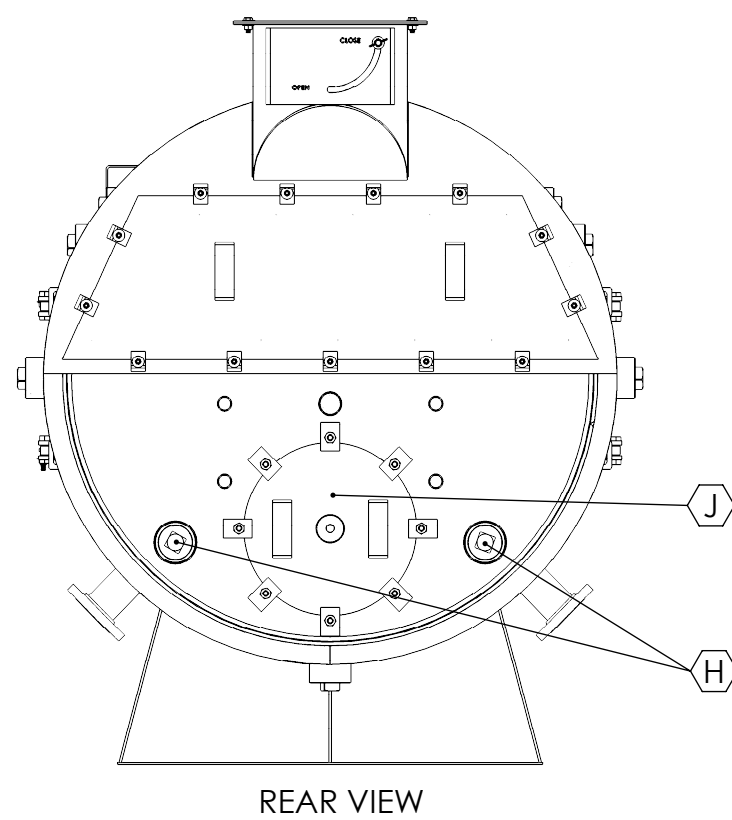
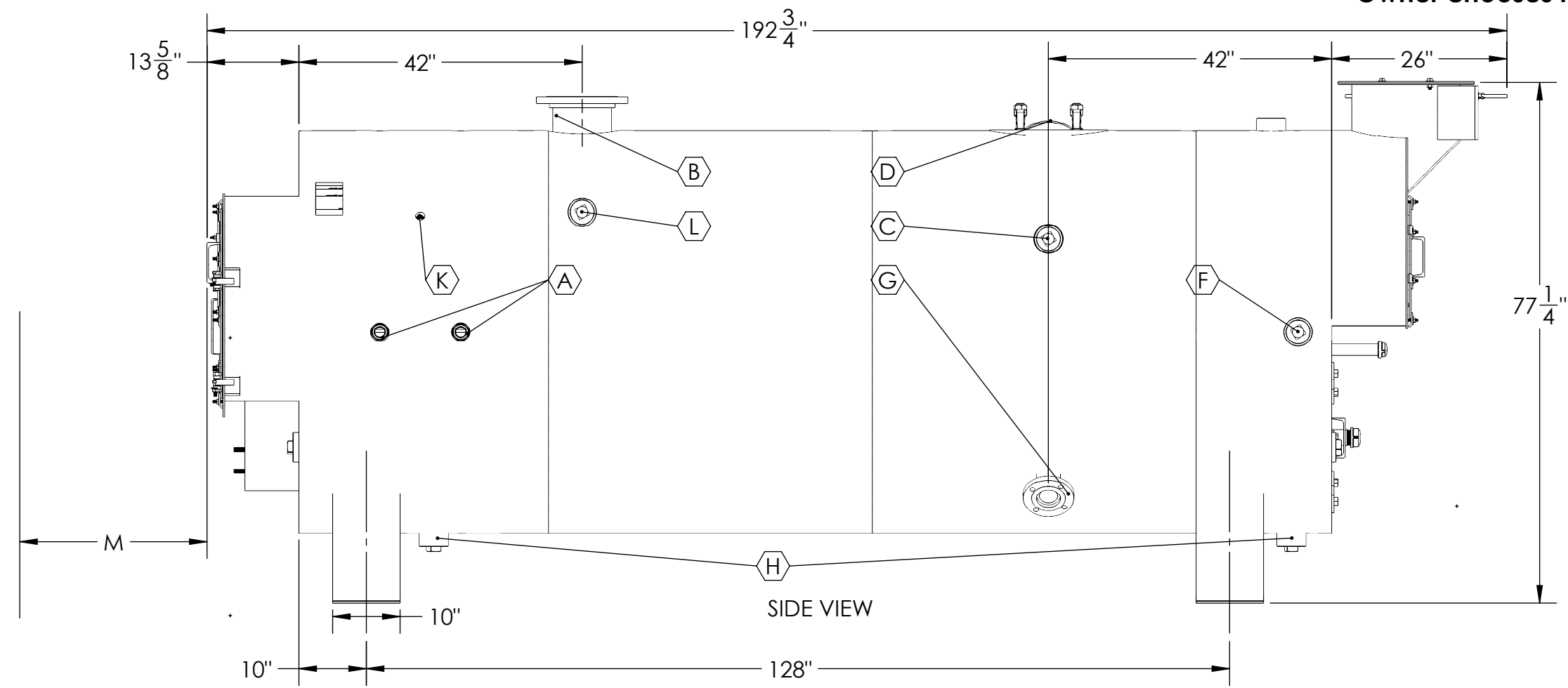
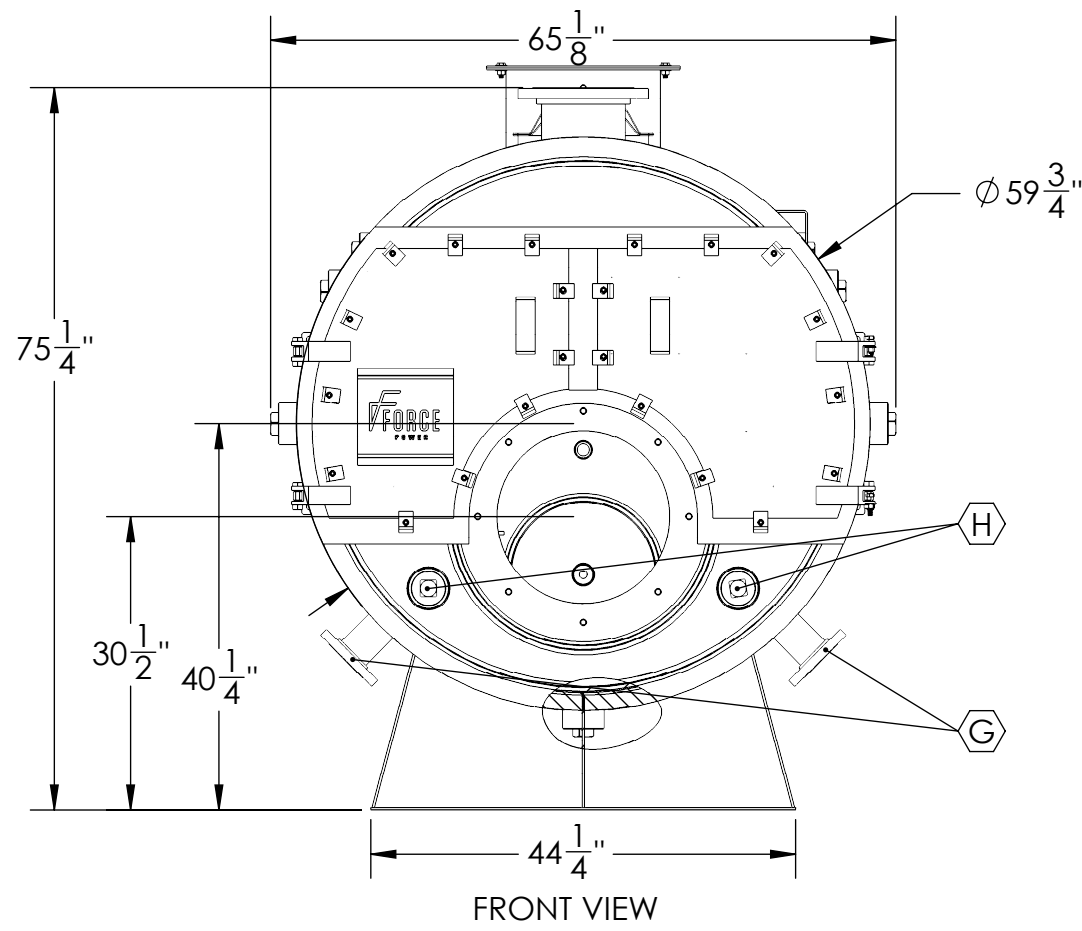

1. ADEQUATE BOIL OUT PROCEDURES MUST BE IMPLEMENTED BEFORE BOILER PLACED IN SERVICE (SEE OPERATION MANUAL).
2. PROPER WATER TREATMENT PROGRAM IS CRITICAL TO THE OPERATION OF THIS BOILER.
3. WARRANTIES, EXPRESSED OR IMPLIED, WILL BE RENDERED NULL AND VOID IF PROPER WATER TREATMENT PROGRAM IS NOT IMPLEMENTED AND MAINTAINED. CONSULT LOCAL WATER TREATMENT SPECIALISTS FOR DESIGN AND SUPPLY OF REQUIRED WATER TREATMENT SYSTEM
4. ALL DOMENSIONS FOR REFERENCE ONLY.

PROPRIETARY AND CONFIDENTIAL
 THE INFORMATION CONTAINED IN THIS DRAWING IS THE SOLE PROPERTY OF FORCE POWER. ANY REPRODUCTION IN PART OR AS A WHOLE WITHOUT THE WRITTEN PERMISSION OF FORCE POWER IS PROHIBITED.

UNLESS OTHERWISE SPECIFIED: DIMENSIONS ARE IN INCHES TOLERANCES: ANGULAR: ± 0.25° TWO PLACE DECIMAL ± .010" THREE PLACE DECIMAL ± .005" SURFACE FINISH		NAME	DATE	30 Commerce Park Drive Niskayuna, NY, 12309, USA PH. (518) 377-2349, FAX (518) 344-7495
DRAWN	SR	10/30/2015	TITLE: TCS-90 Boiler ASSY (3p)	
CHECKED			SIZE	DWG. NO.
ENG APPR.			C	50902_SM
MFG APPR.			SCALE: 1:48	WEIGHT: 10009.644
Q.A.			REV	---
COMMENTS:			SHEET 1 OF 1	
NEXT ASSY	USED ON	FINISH	DO NOT SCALE DRAWING	
APPLICATION				

4

3

2

1