

4

3

2

1

BOILER DATA	
OPERATING VOLUME (USG)	680
OPERATING WEIGHT (LBS)	13600
HEAT INPUT (MBH)	2860
OUTPUT (HP)	70

VENT FLANGE DIMENSIONS	
OD	20-1/8
ID	16
B.C.D.	18.5
NO. OF HOLES	8
HOLE DIAMETER	1/2

CONNECTION SCHEDULE				
TAG	DESCRIPTION	CONNECTION		
		SIZE (INCH)	TYPE	RATING
A	CONTROLS	1-1/4	FULL COUPLING	3000#
B	STEAM OUTLETS	8	SORF FLANGE	150#
C	SURFACE BLOWDOWN	3	FULL COUPLING	3000#
D	MANHOLE	12X16	ELLIPTICAL	
E	SAFETY RELIEF VALVE	2-1/2	FULL COUPLING	3000#
F	REVERSING CHAMBER WASHOUT	3	FULL COUPLING	3000#
G	CONDENSATE INLET	3	SORF FLANGE	150#
H	WASHOUTS	3	FULL COUPLING	3000#
J	REAR DOOR	20		
K	LOW FIRE HOLD	3/4	FULL COUPLING	3000#
L	FURNACE INSPECTION	3	FULL COUPLING	3000#
M	TUBE PULL	120		

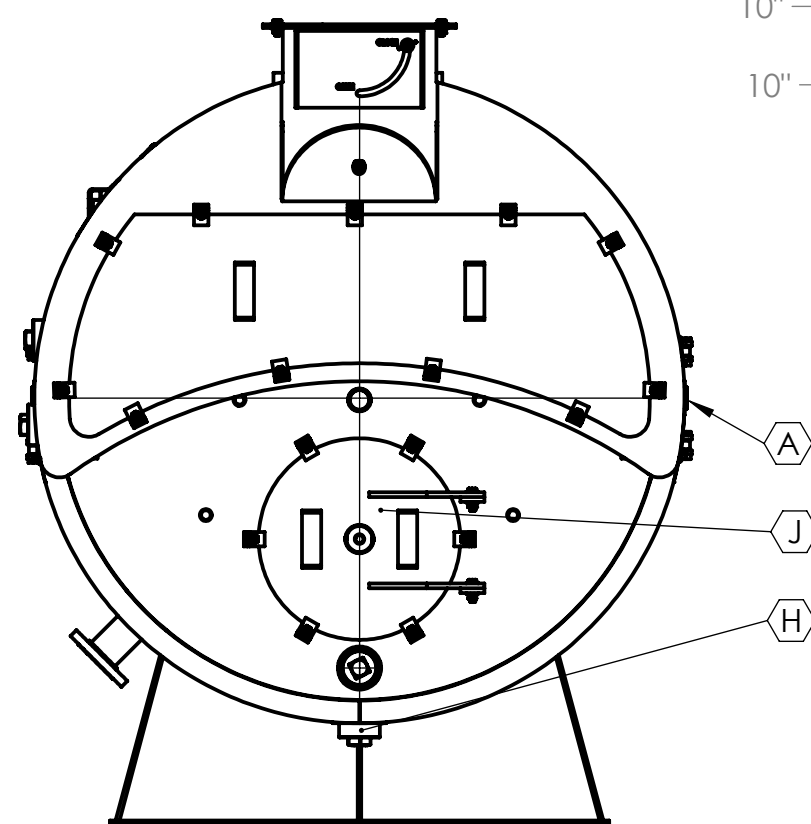
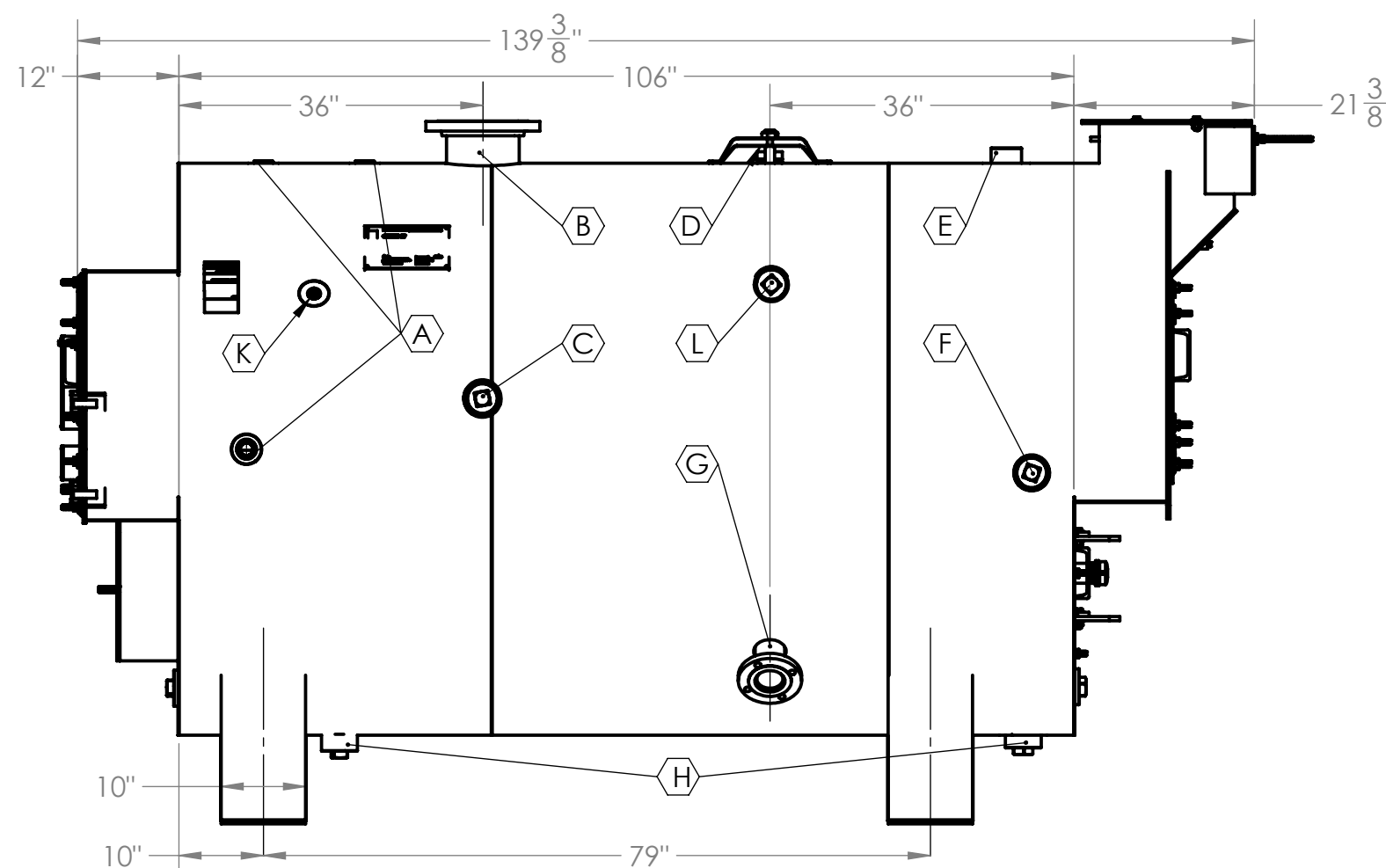
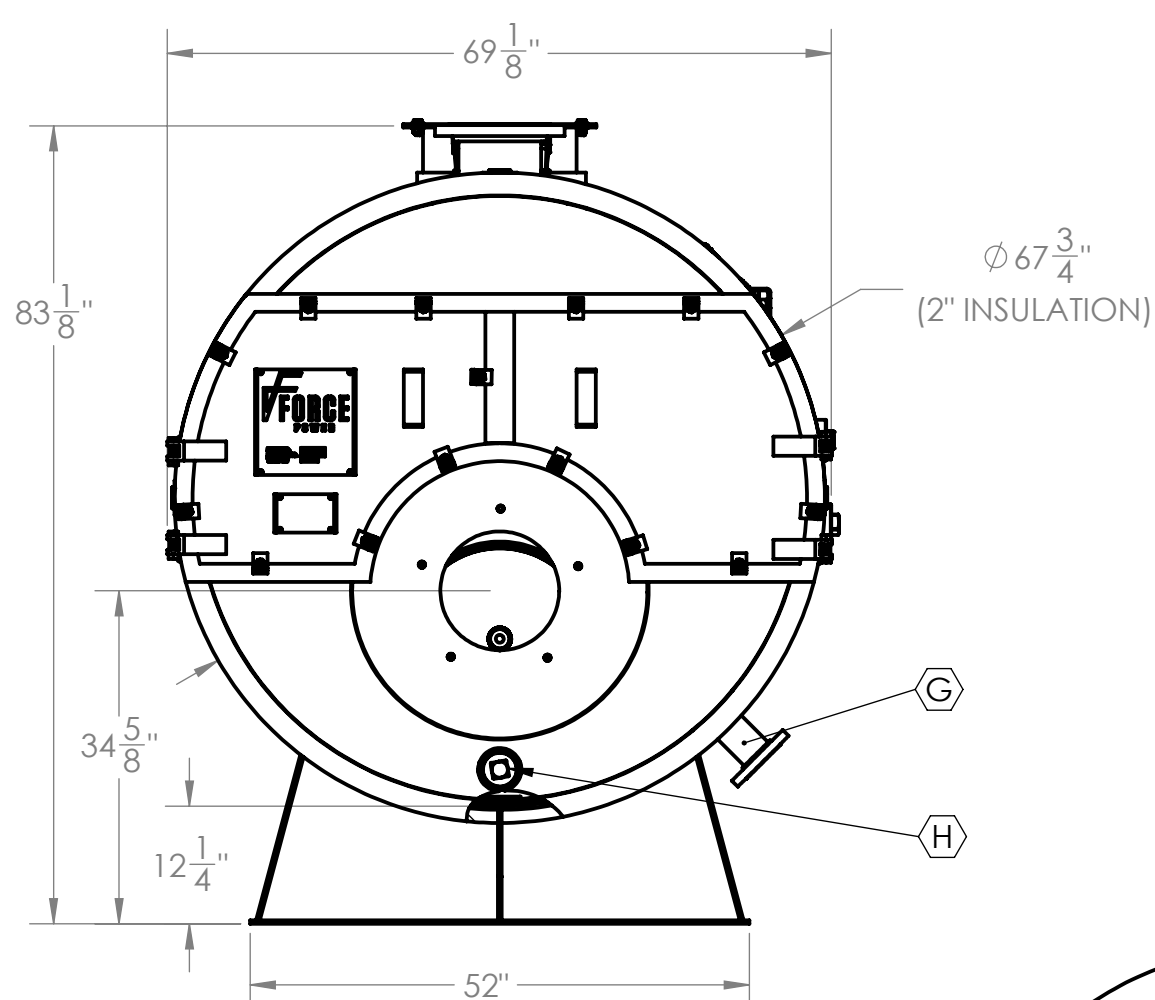

1. ADEQUATE BOIL OUT PROCEDURES MUST BE IMPLEMENTED BEFORE BOILER PLACED IN SERVICE (SEE OPERATION MANUAL).
2. PROPER WATER TREATMENT PROGRAM IS CRITICAL TO THE OPERATION OF THIS BOILER.
3. WARRANTIES, EXPRESSED OR IMPLIED, WILL BE RENDERED NULL AND VOID IF PROPER WATER TREATMENT PROGRAM IS NOT IMPLEMENTED AND MAINTAINED. CONSULT LOCAL WATER TREATMENT SPECIALISTS FOR DESIGN AND SUPPLY OF REQUIRED WATER TREATMENT SYSTEM
4. ALL DIMENSIONS FOR REFERENCE ONLY.

**PROPRIETARY AND CONFIDENTIAL**  
 THE INFORMATION CONTAINED IN THIS DRAWING IS THE SOLE PROPERTY OF FORCE POWER. ANY REPRODUCTION IN PART OR AS A WHOLE WITHOUT THE WRITTEN PERMISSION OF FORCE POWER IS PROHIBITED.

UNLESS OTHERWISE SPECIFIED: DIMENSIONS ARE IN INCHES		DRAWN	NAME	DATE	 30 Commerce Park Drive Niskayuna, NY, 12309, USA PH. (518) 377-2349, FAX (518) 344-7495
TOLERANCES: ANGULAR: ±5° .XX: ±.010" .XXX: ±.005" FRACTIONS: ± 1/16"		CHECKED	SR	12/2/2016	
INTERPRET GEOMETRIC TOLERANCING PER: ANSI Y14.5		ENG APPR.			
MATERIAL SEE NOTE 1		MFG APPR.			
FINISH SEE NOTE 3	COMMENTS:				TITLE: TCS70LS(XL) Boiler ASSY, 3P-R-FE
APPLICATION	DO NOT SCALE DRAWING				SIZE DWG. NO. REV <b>C</b> 5007221200 <b>A</b> SCALE: 1:48 WEIGHT: 7410.7325 SHEET 1 OF 1

4

3

2

1