

4

3

2

1

BOILER DATA	
OPERATING VOLUME (USG)	770
OPERATING WEIGHT (LBS)	14200
HEAT INPUT (MBH)	2450
OUTPUT (HP)	60

VENT FLANGE DIMENSIONS	
OD	20-1/8
ID	16
B.C.D.	18.5
NO. OF HOLES	8
HOLE DIAMETER	1/2

CONNECTION SCHEDULE				
TAG	DESCRIPTION	CONNECTION		
		SIZE (INCH)	TYPE	RATING
A	CONTROLS	1-1/4	FULL COUPLING	3000#
B	WATER OUTLET	4	SORF FLANGE	150#
C	SURFACE BLOWDOWN	3	FULL COUPLING	3000#
D	MANHOLE	12X16	ELLIPTICAL	
E	SAFETY RELIEF VALVE	2-1/2	FULL COUPLING	3000#
F	REVERSING CHAMBER WASHOUT	3	FULL COUPLING	3000#
G	WATER INLET	4	SORF FLANGE	150#
H	WASHOUTS	3	FULL COUPLING	3000#
J	REAR ACCESS DOOR	20		
K	CONTROLS	3/4	FULL COUPLING	3000#
L	FURNACE INSPECTION	3	FULL COUPLING	3000#
M	TUBE PULL	92		

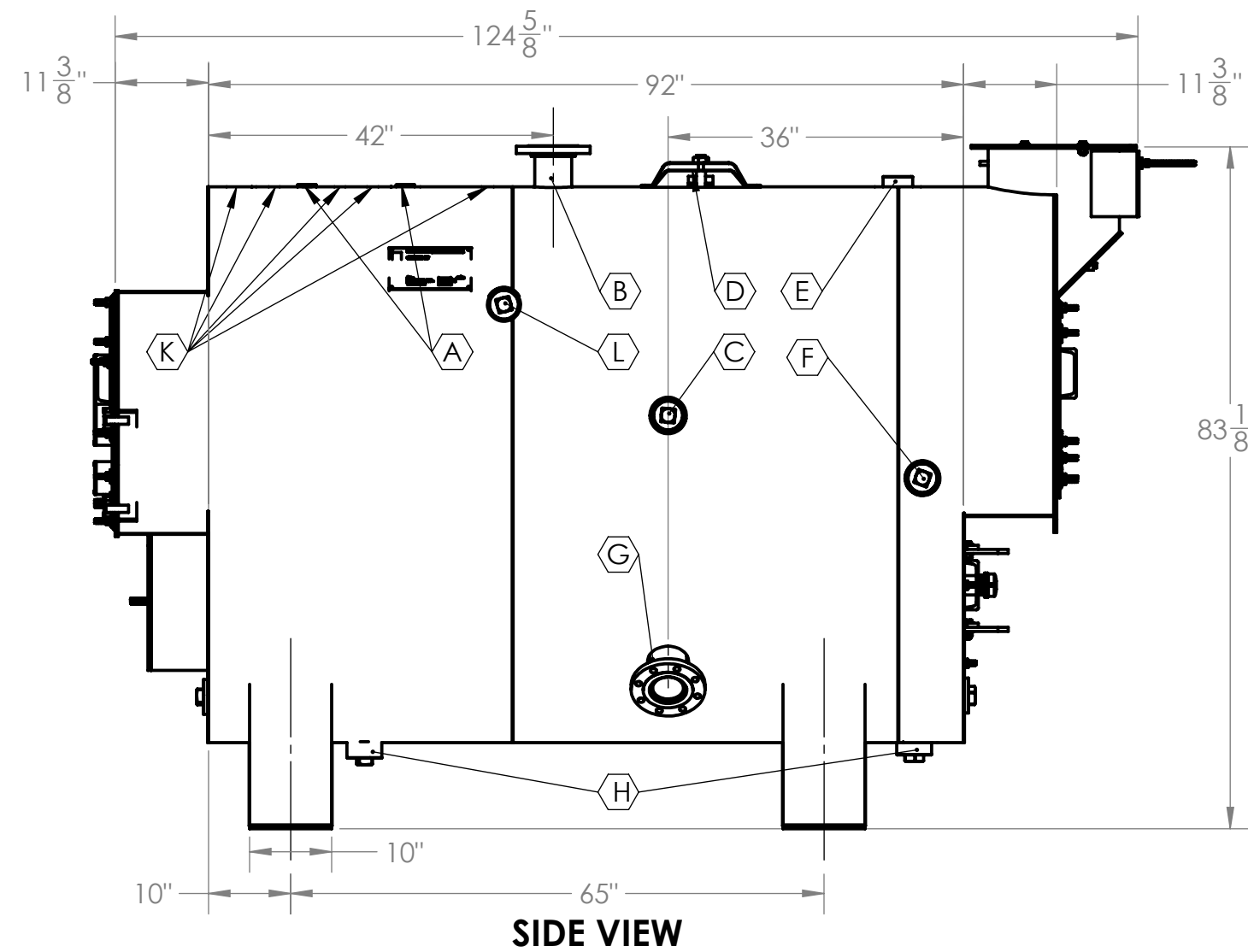
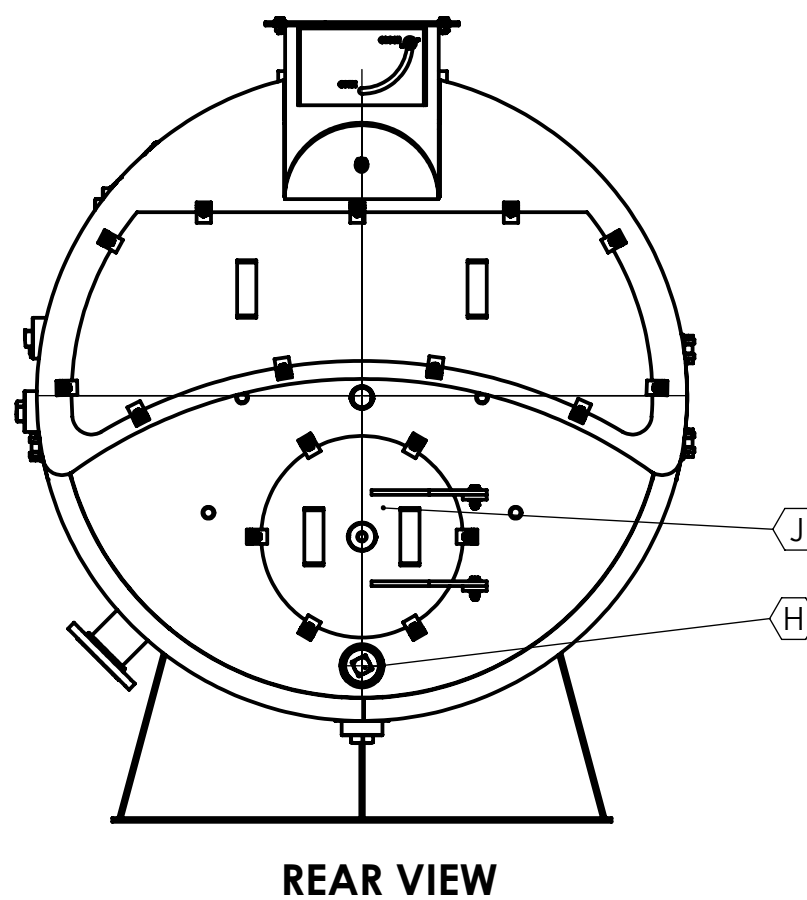
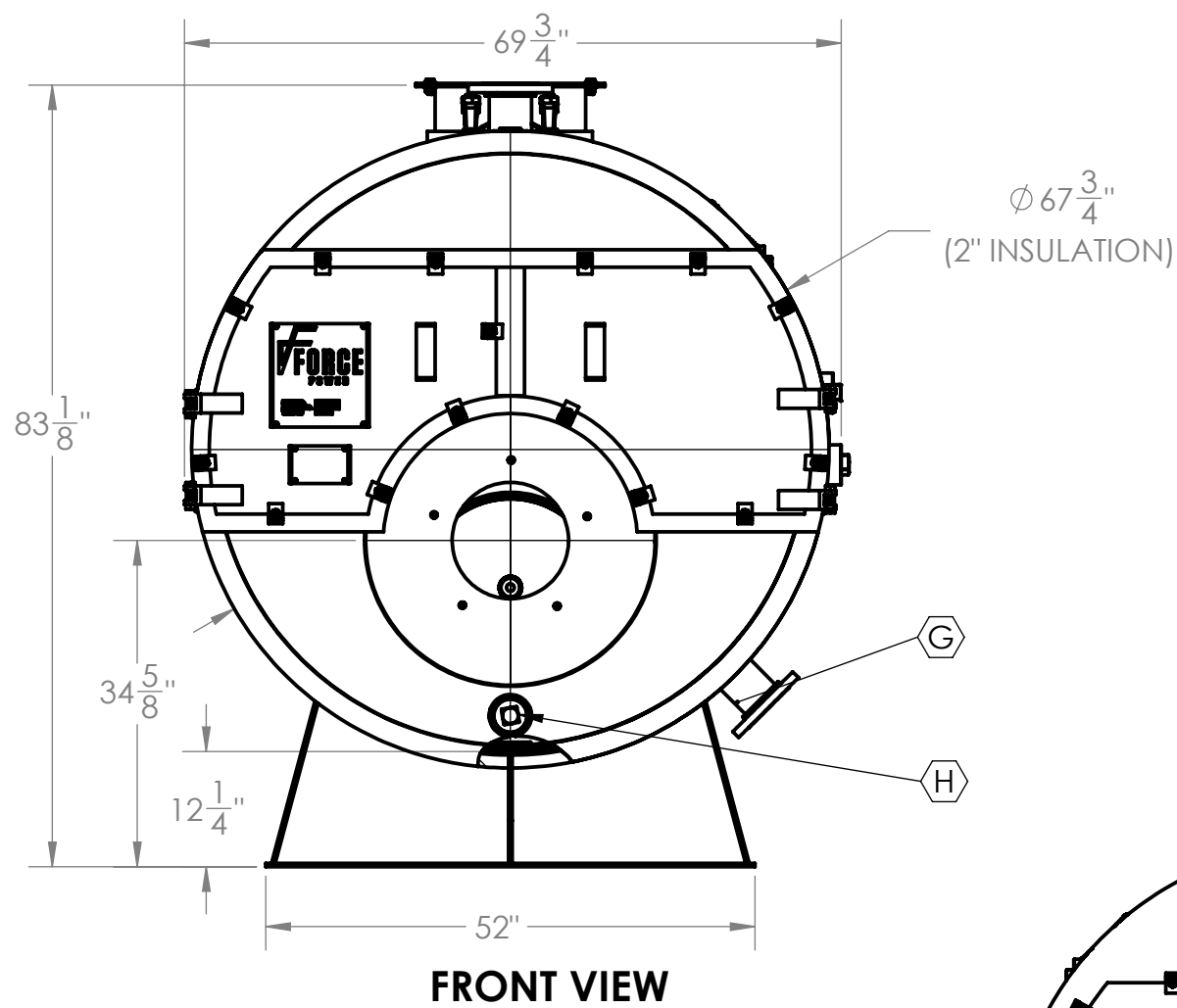

1. ADEQUATE BOIL OUT PROCEDURES MUST BE IMPLEMENTED BEFORE BOILER PLACED IN SERVICE (SEE OPERATION MANUAL).
2. PROPER WATER TREATMENT PROGRAM IS CRITICAL TO THE OPERATION OF THIS BOILER.
3. WARRANTIES, EXPRESSED OR IMPLIED, WILL BE RENDERED NULL AND VOID IF PROPER WATER TREATMENT PROGRAM IS NOT IMPLEMENTED AND MAINTAINED. CONSULT LOCAL WATER TREATMENT SPECIALISTS FOR DESIGN AND SUPPLY OF REQUIRED WATER TREATMENT SYSTEM
4. ALL DIMENSIONS FOR REFERENCE ONLY.

PROPRIETARY AND CONFIDENTIAL
THE INFORMATION CONTAINED IN THIS DRAWING IS THE SOLE PROPERTY OF FORCE POWER. ANY REPRODUCTION IN PART OR AS A WHOLE WITHOUT THE WRITTEN PERMISSION OF FORCE POWER IS PROHIBITED.

UNLESS OTHERWISE SPECIFIED:		NAME	DATE
DIMENSIONS ARE IN INCHES		SR	12/16/2016
TOLERANCES:			
ANGULAR: ± 5°			
.XX: ± .010"			
.XXX: ± .005"			
FRACTIONS: ± 1/16"			
INTERPRET GEOMETRIC TOLERANCING PER: ANSI Y14.5			
MATERIAL: SEE NOTE 1			
FINISH: SEE NOTE 3			
NEXT ASSY	USED ON		
APPLICATION	DO NOT SCALE DRAWING		

30 Commerce Park Drive
Niskayuna, NY, 12309, USA
PH. (518) 377-2349, FAX (518) 344-7495

FORGE

TITLE: TCS60W(XL) Boiler ASSY, 3P-R-FE

SIZE DWG. NO. REV
C 5006121200 --

SCALE: 1:48 WEIGHT: 6779.1132 SHEET 1 OF 1

4

3

2

1