

4

3

2

1

BOILER DATA	
OPERATING VOLUME (USG)	650
OPERATING WEIGHT (LBS)	12800
HEAT INPUT (MBH)	2450
OUTPUT (HP)	60

VENT FLANGE DIMENSIONS	
OD	20-1/8
ID	16
B.C.D.	18.5
NO. OF HOLES	8
HOLE DIAMETER	1/2

CONNECTION SCHEDULE				
TAG	DESCRIPTION	CONNECTION		
		SIZE (INCH)	TYPE	RATING
A	CONTROLS	1	FULL COUPLING	3000#
B	WATER SUPPLY, NPS	4	SORF FLANGE	150#
C*	SURFACE BLOWDOWN	3	FULL COUPLING	3000#
D	MANHOLE	12X16	ELLIPTICAL	
E	SAFETY RELIEF VALVE	3	FULL COUPLING	3000#
F*	REVERSING CHAMBER WASHOUT	3	FULL COUPLING	3000#
G*	WATER RETURN, NPS	4	SORF FLANGE	150#
H	WASHOUTS	3	FULL COUPLING	3000#
J	REAR DOOR	16		
K	THERMOSENSOR	1/2	FULL COUPLING	3000#
L*	FURNACE INSPECTION	3	FULL COUPLING	3000#
M	TUBE PULL	155		
N	PRESSURE GAGE	1/2	FULL COUPLING	3000#

*- Owner chooses left/right installation

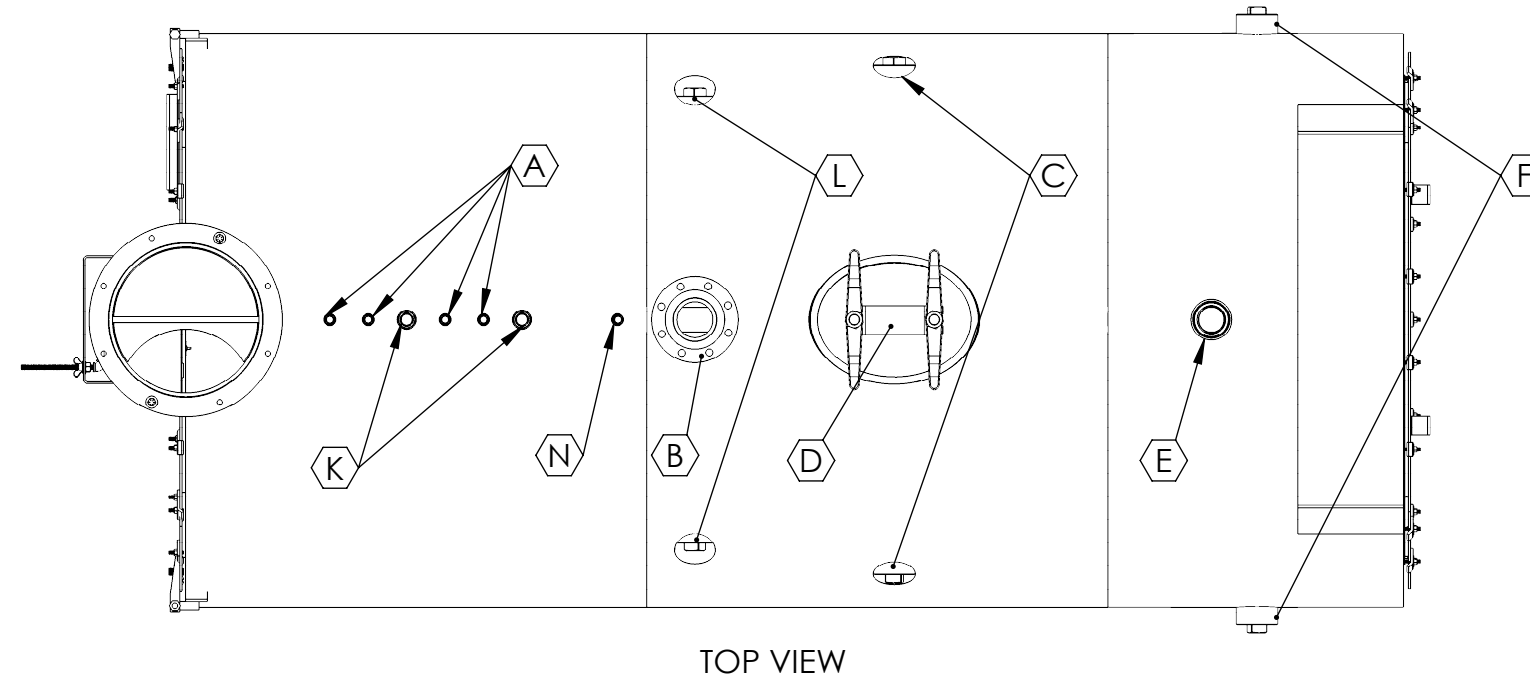
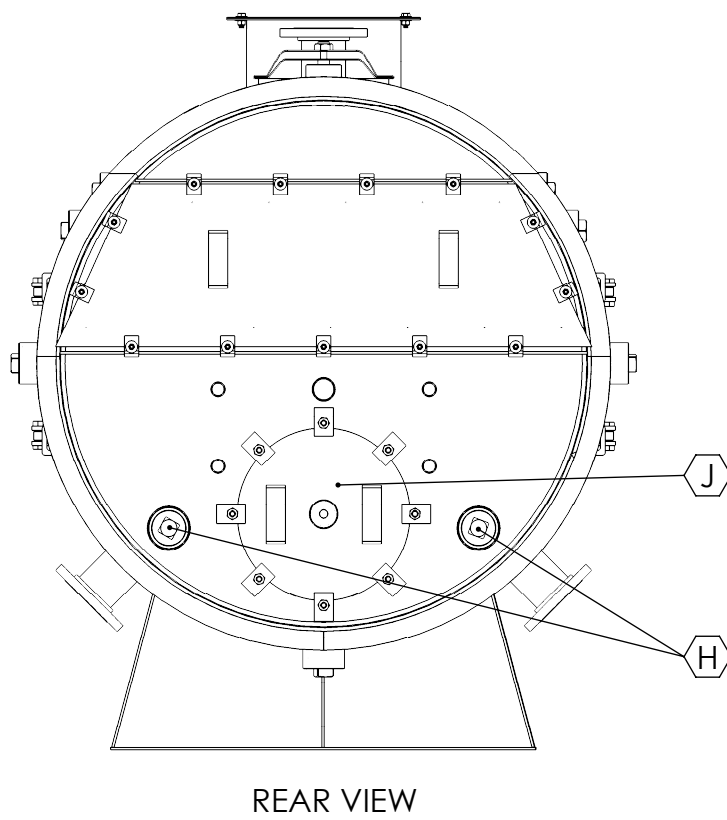
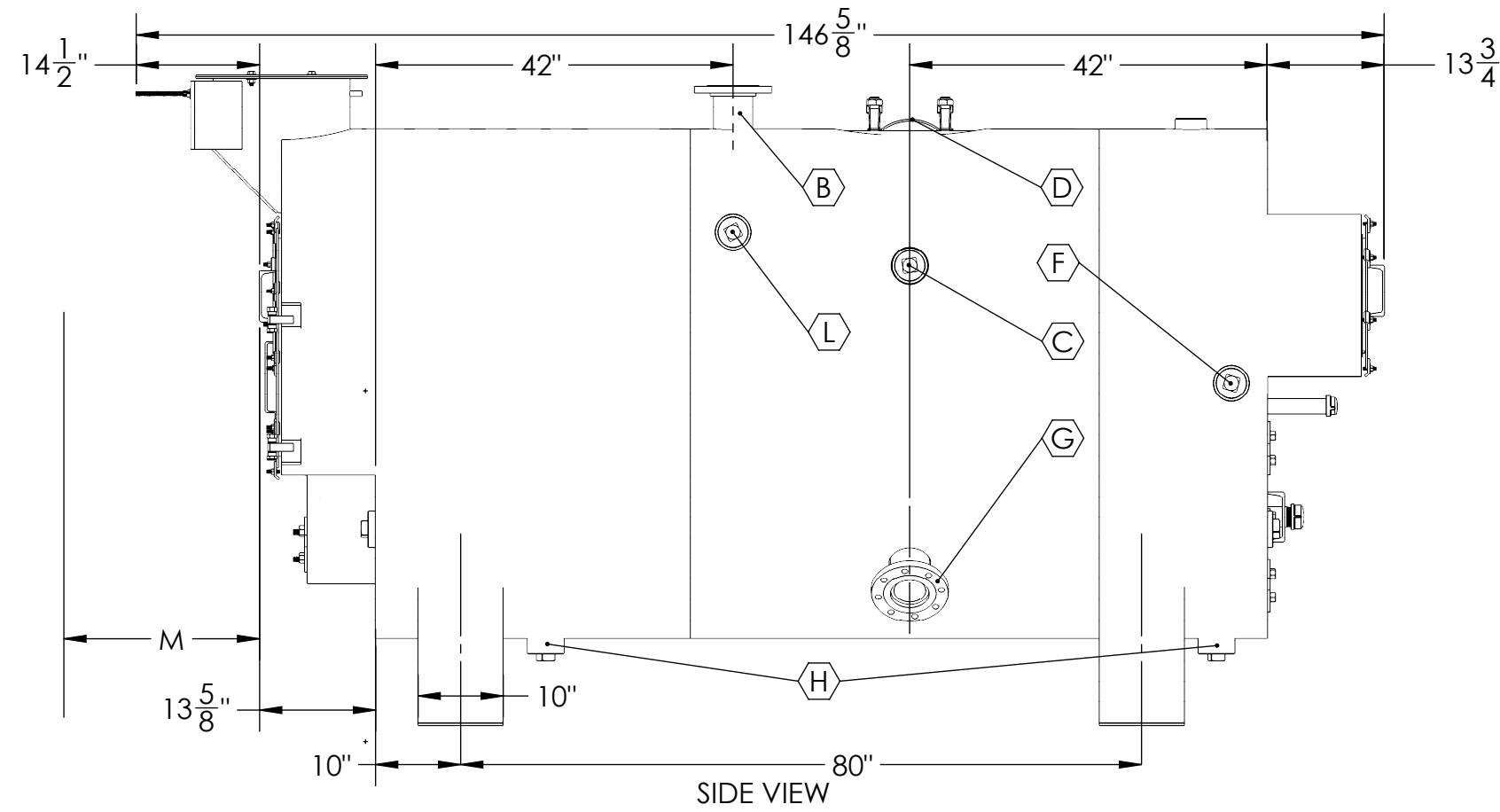
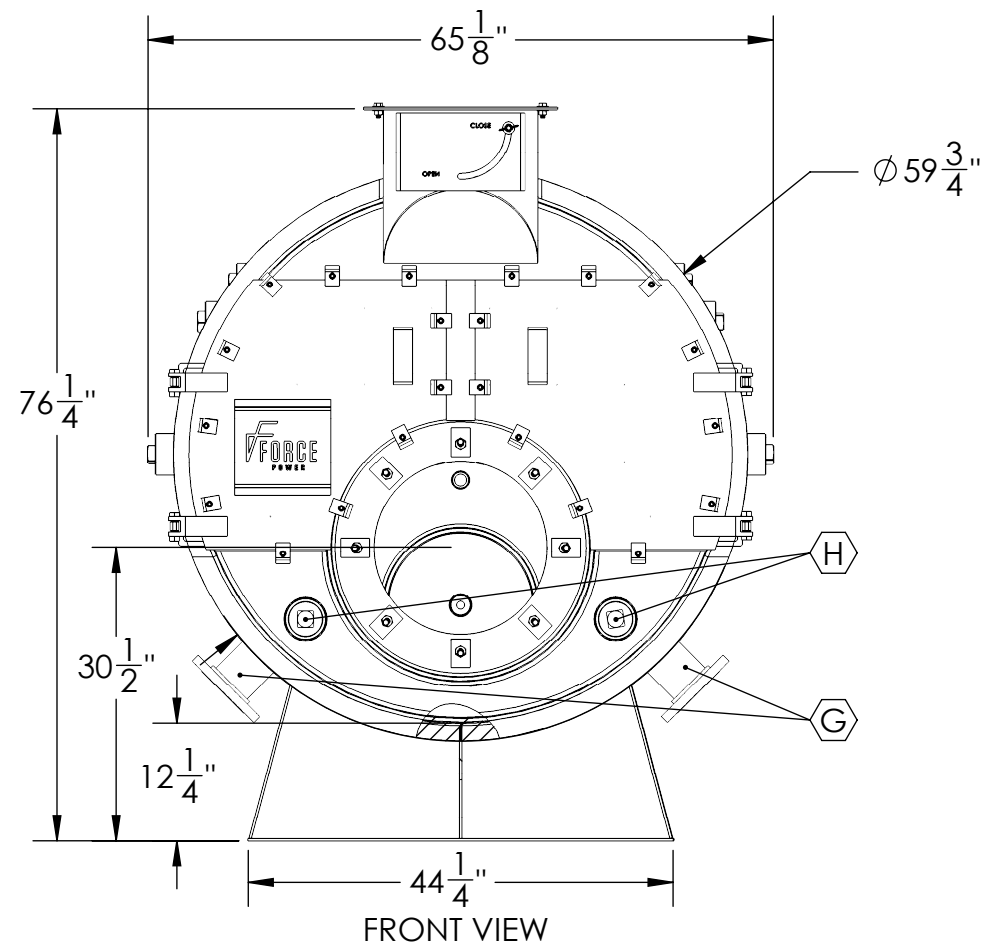

1. ADEQUATE BOIL OUT PROCEDURES MUST BE IMPLEMENTED BEFORE BOILER PLACED IN SERVICE (SEE OPERATION MANUAL).
2. PROPER WATER TREATMENT PROGRAM IS CRITICAL TO THE OPERATION OF THIS BOILER.
3. WARRANTIES, EXPRESSED OR IMPLIED, WILL BE RENDERED NULL AND VOID IF PROPER WATER TREATMENT PROGRAM IS NOT IMPLEMENTED AND MAINTAINED. CONSULT LOCAL WATER TREATMENT SPECIALISTS FOR DESIGN AND SUPPLY OF REQUIRED WATER TREATMENT SYSTEM
4. ALL DIMENSIONS FOR REFERENCE ONLY.

PROPRIETARY AND CONFIDENTIAL
 THE INFORMATION CONTAINED IN THIS DRAWING IS THE SOLE PROPERTY OF FORCE POWER. ANY REPRODUCTION IN PART OR AS A WHOLE WITHOUT THE WRITTEN PERMISSION OF FORCE POWER IS PROHIBITED.

UNLESS OTHERWISE SPECIFIED:		DRAWN		NAME	DATE	30 Commerce Park Drive Niskayuna, NY, 12309, USA PH. (518) 377-2349, FAX (518) 344-7495
DIMENSIONS ARE IN INCHES		CHECKED		SR	10/30/2015	
TOLERANCES:		ENG APPR.				
ANGULAR: ± 0.25°		MFG APPR.				
TWO PLACE DECIMAL ± .010"		Q.A.				
THREE PLACE DECIMAL ± .005"		COMMENTS:				
SURFACE FINISH						
INTERPRET GEOMETRIC TOLERANCING PER: ANSI Y14.5						
MATERIAL SEE NOTE 1						
FINISH SEE NOTE 3						
APPLICATION						
DO NOT SCALE DRAWING						

TCS-60W Boiler ASSY (4p)

SIZE	DWG. NO.	REV
C	50611_SM	-
SCALE: 1:48		WEIGHT: 7370.229
		SHEET 1 OF 1

4

3

2

1