

4

3

2

1

BOILER DATA

OPERATING VOLUME (USG)	4470
OPERATING WEIGHT (LBS)	69500
HEAT INPUT (MBH)	20420
OUTPUT (HP)	500

VENT FLANGE DIMENSIONS

OD	38-1/4
ID	32
B.C.D.	36
NO. OF HOLES	12
HOLE DIAMETER	3/4

CONNECTION SCHEDULE

TAG	DESCRIPTION	CONNECTION		
		SIZE (INCH)	TYPE	RATING
A	CONTROLS	1	FULL COUPLING	3000#
B	WATER SUPPLY, NPS	4	SORF FLANGE	150#
C*	SURFACE BLOWDOWN	3	FULL COUPLING	3000#
D	MANHOLE	12X16	ELLIPTICAL	
E	SAFETY RELIEF VALVE	3	FULL COUPLING	3000#
F*	REVERSING CHAMBER WASHOUT	3	FULL COUPLING	3000#
G*	WATER RETURN, NPS	4	SORF FLANGE	150#
H	WASHOUTS	3	FULL COUPLING	3000#
J	REAR DOOR	16		
K	THERMOSENSOR	1/2	FULL COUPLING	3000#
L*	FURNACE INSPECTION	3	FULL COUPLING	3000#
M	TUBE PULL	155		
N	PRESSURE GAGE	1/2	FULL COUPLING	3000#

* - Owner chooses left/right installation

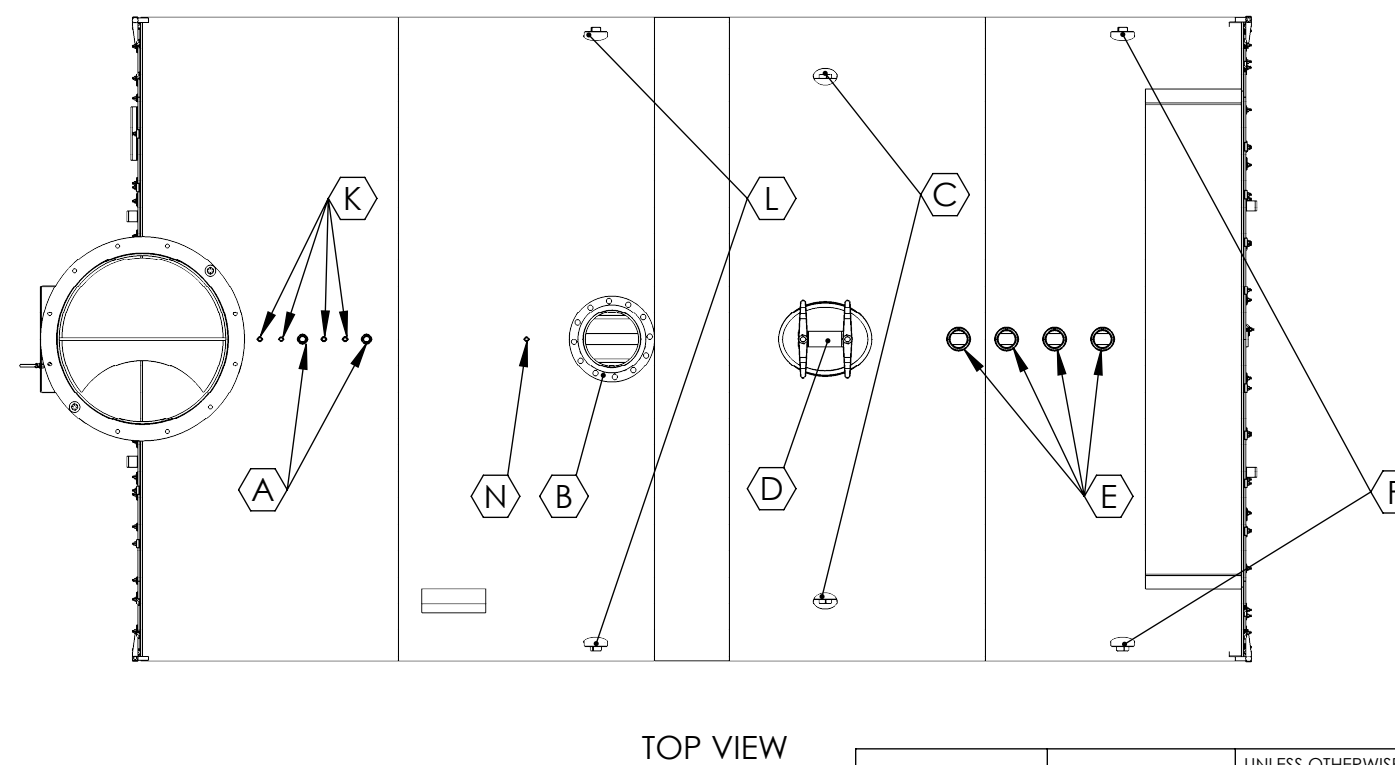
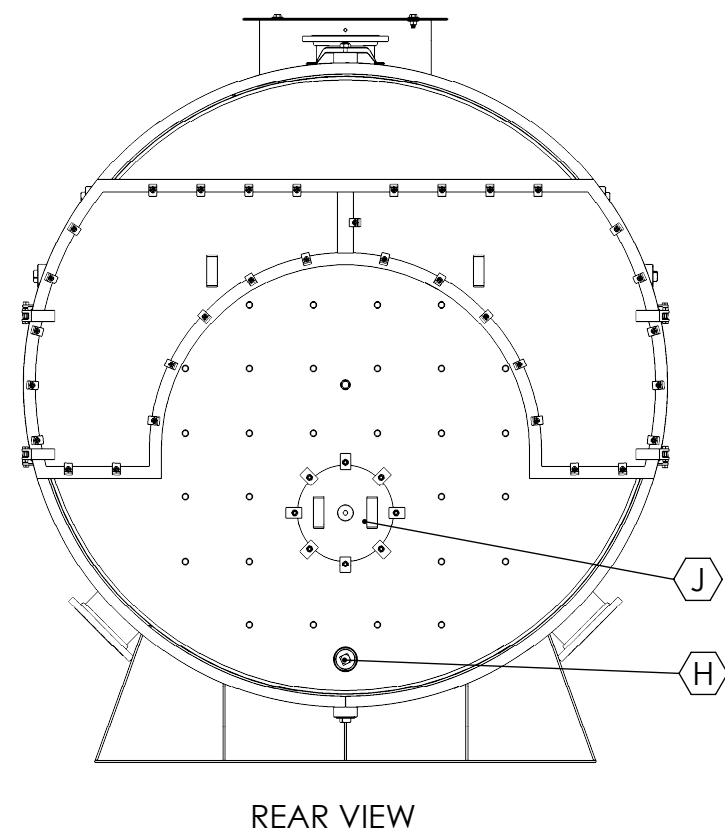
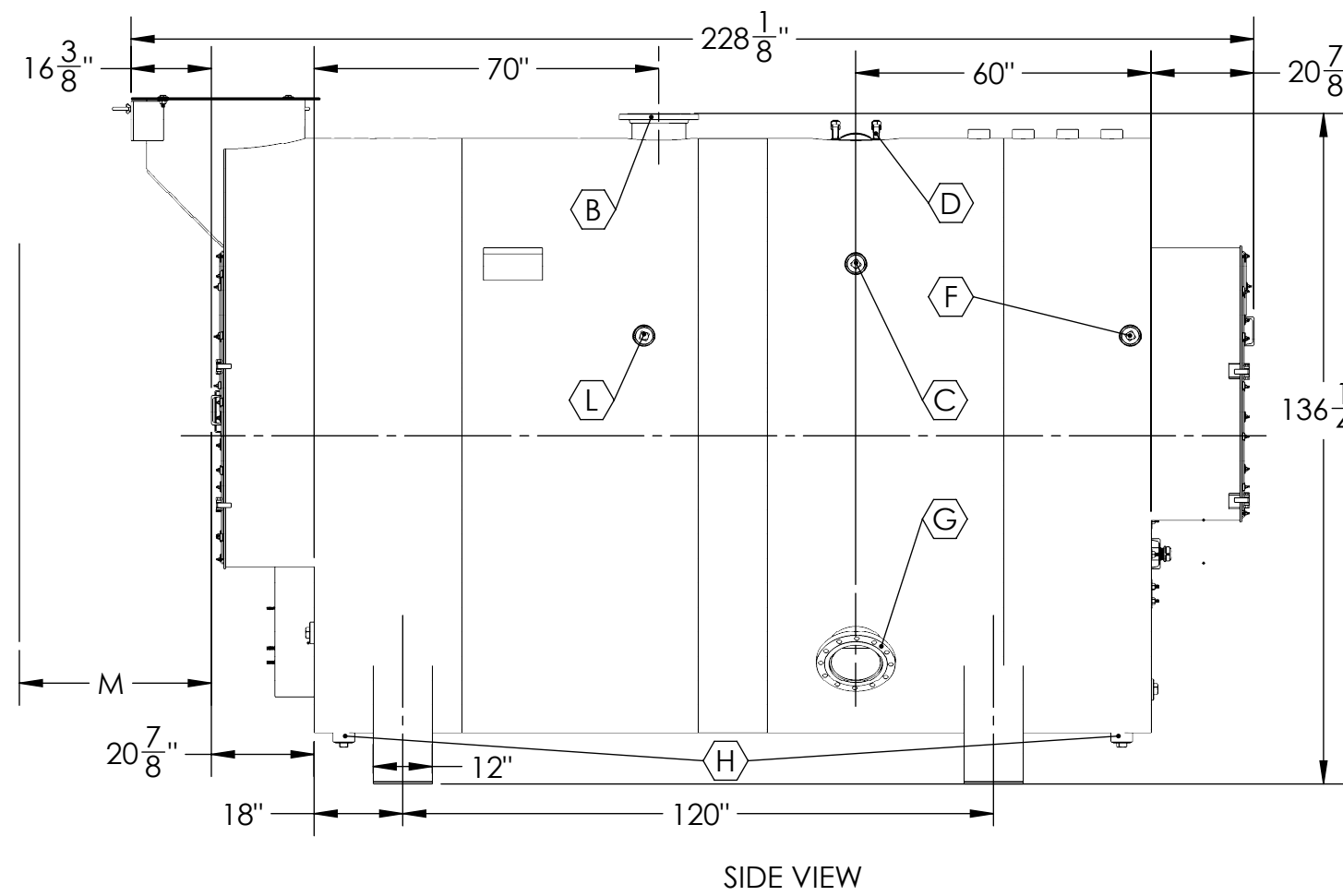
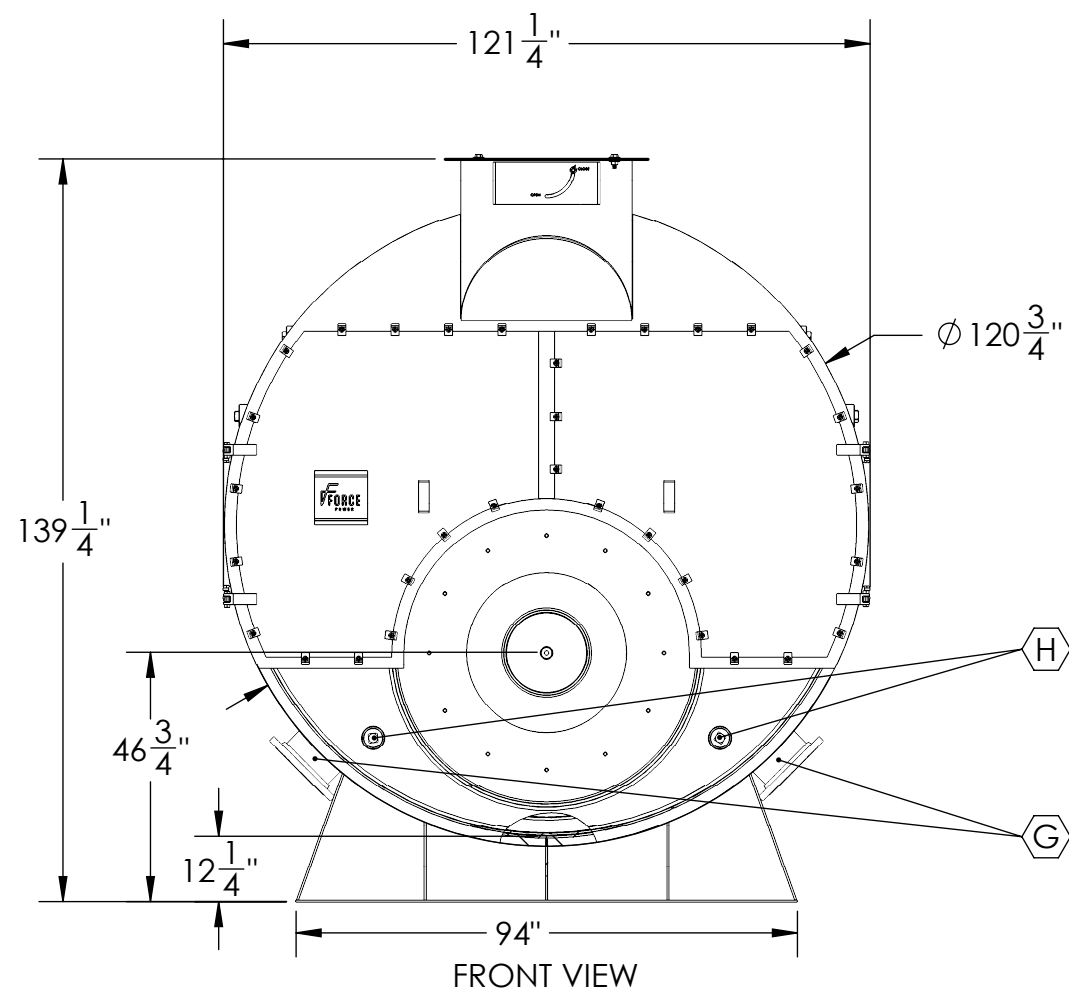

1. ADEQUATE BOIL OUT PROCEDURES MUST BE IMPLEMENTED BEFORE BOILER PLACED IN SERVICE (SEE OPERATION MANUAL).
2. PROPER WATER TREATMENT PROGRAM IS CRITICAL TO THE OPERATION OF THIS BOILER.
3. WARRANTIES, EXPRESSED OR IMPLIED, WILL BE RENDERED NULL AND VOID IF PROPER WATER TREATMENT PROGRAM IS NOT IMPLEMENTED AND MAINTAINED. CONSULT LOCAL WATER TREATMENT SPECIALISTS FOR DESIGN AND SUPPLY OF REQUIRED WATER TREATMENT SYSTEM.
4. ALL DIMENSIONS FOR REFERENCE ONLY.

PROPRIETARY AND CONFIDENTIAL
 THE INFORMATION CONTAINED IN THIS DRAWING IS THE SOLE PROPERTY OF FORCE POWER. ANY REPRODUCTION IN PART OR AS A WHOLE WITHOUT THE WRITTEN PERMISSION OF FORCE POWER IS PROHIBITED.

UNLESS OTHERWISE SPECIFIED:		NAME	DATE	30 Commerce Park Drive Niskayuna, NY, 12309, USA PH. (518) 377-2349, FAX (518) 344-7495
DIMENSIONS ARE IN INCHES		DRAWN	SR	
TOLERANCES:		CHECKED		TITLE:
ANGULAR: ± 0.25°		ENG APPR.		TCS 500W (4p)
TWO PLACE DECIMAL ± .010"		MFG APPR.		Boiler ASSY
THREE PLACE DECIMAL ± .005"		Q.A.		SIZE DWG. NO. REV
SURFACE FINISH		COMMENTS:		C 55011_SM -
INTERPRET GEOMETRIC TOLERANCING PER: ANSI Y14.5				SCALE: 1:48 WEIGHT: 36801.66 SHEET 1 OF 1
MATERIAL SEE NOTE 1				
FINISH SEE NOTE 3				
NEXT ASSY	USED ON			
APPLICATION	DO NOT SCALE DRAWING			

4

3

2

1