

4

3

2

1

BOILER DATA

OPERATING VOLUME (USG)	2900
OPERATING WEIGHT (LBS)	43400
HEAT INPUT (MBH)	12250
OUTPUT (HP)	300

VENT FLANGE DIMENSIONS

OD	25
ID	20
B.C.D.	22.5
NO. OF HOLES	8
HOLE DIAMETER	1/2

CONNECTION SCHEDULE

TAG	DESCRIPTION	CONNECTION		
		SIZE (INCH)	TYPE	RATING
A	CONTROLS	1	FULL COUPLING	3000#
B	WATER SUPPLY, NPS	4	SORF FLANGE	150#
C*	SURFACE BLOWDOWN	3	FULL COUPLING	3000#
D	MANHOLE	12X16	ELLIPTICAL	
E	SAFETY RELIEF VALVE	3	FULL COUPLING	3000#
F*	REVERSING CHAMBER WASHOUT	3	FULL COUPLING	3000#
G*	WATER RETURN, NPS	4	SORF FLANGE	150#
H	WASHOUTS	3	FULL COUPLING	3000#
J	REAR DOOR	16		
K	THERMOSENSOR	1/2	FULL COUPLING	3000#
L*	FURNACE INSPECTION	3	FULL COUPLING	3000#
M	TUBE PULL	155		
N	PRESSURE GAGE	1/2	FULL COUPLING	3000#

* - Owner chooses left/right installation

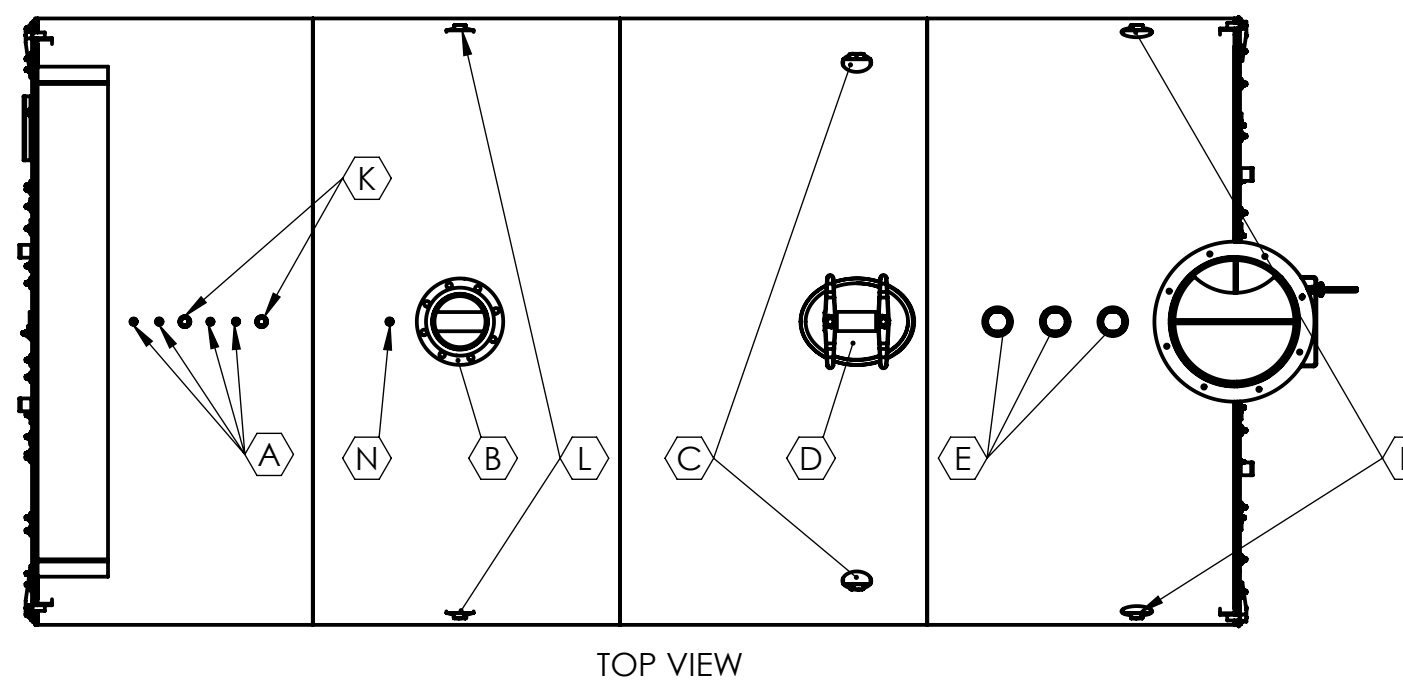
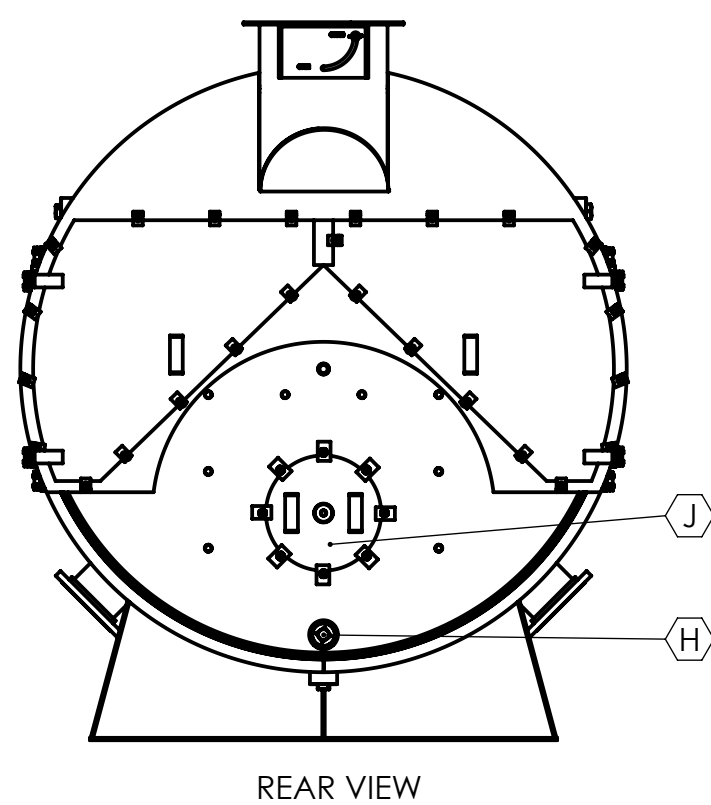
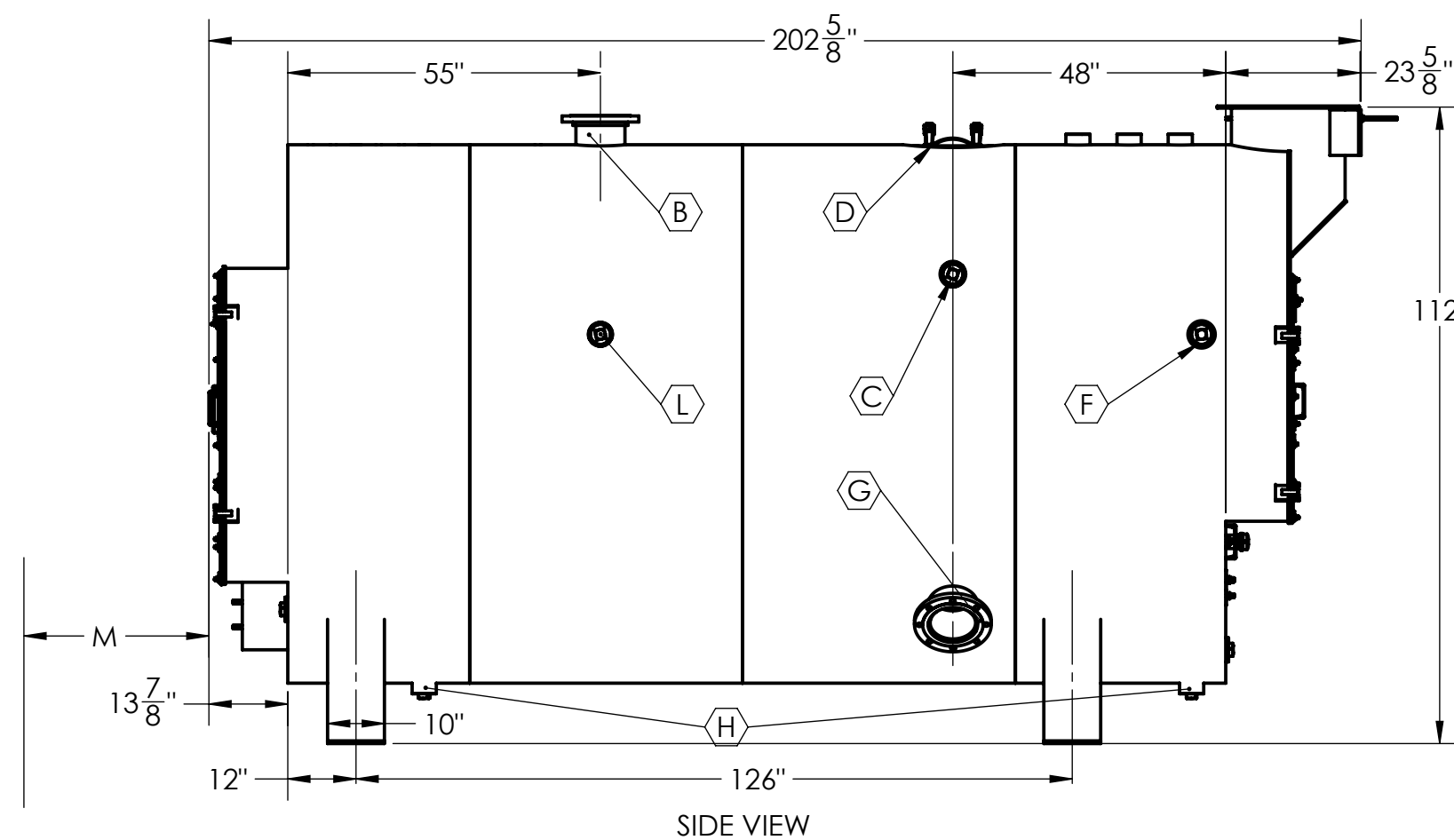
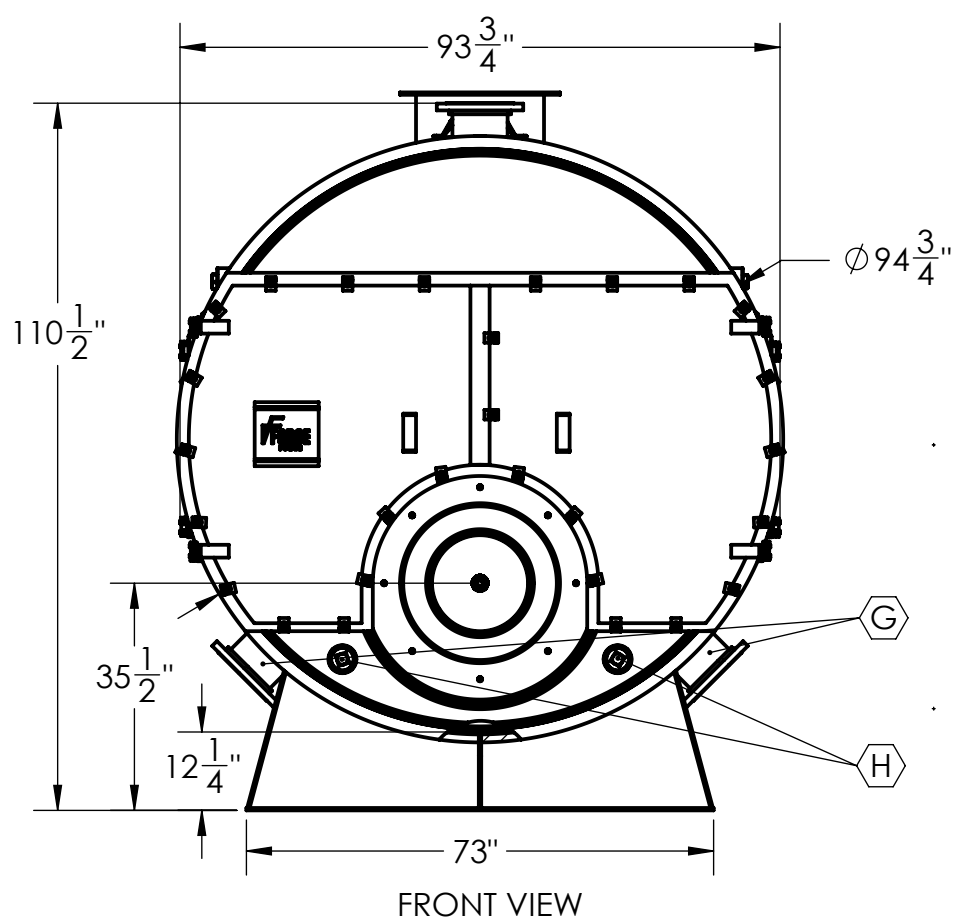

1. ADEQUATE BOIL OUT PROCEDURES MUST BE IMPLEMENTED BEFORE BOILER PLACED IN SERVICE (SEE OPERATION MANUAL).
2. PROPER WATER TREATMENT PROGRAM IS CRITICAL TO THE OPERATION OF THIS BOILER.
3. WARRANTIES, EXPRESSED OR IMPLIED, WILL BE RENDERED NULL AND VOID IF PROPER WATER TREATMENT PROGRAM IS NOT IMPLEMENTED AND MAINTAINED. CONSULT LOCAL WATER TREATMENT SPECIALISTS FOR DESIGN AND SUPPLY OF REQUIRED WATER TREATMENT SYSTEM.
4. ALL DIMENSIONS FOR REFERENCE ONLY.

PROPRIETARY AND CONFIDENTIAL
 THE INFORMATION CONTAINED IN THIS DRAWING IS THE SOLE PROPERTY OF FORCE POWER. ANY REPRODUCTION IN PART OR AS A WHOLE WITHOUT THE WRITTEN PERMISSION OF FORCE POWER IS PROHIBITED.

UNLESS OTHERWISE SPECIFIED:	NAME	DATE
DIMENSIONS ARE IN INCHES	SR	10/30/2015
TOLERANCES:		
ANGULAR: ± 0.25°		
TWO PLACE DECIMAL ± .010"		
THREE PLACE DECIMAL ± .005"		
SURFACE FINISH		
INTERPRET GEOMETRIC TOLERANCING PER: ANSI Y14.5		
MATERIAL SEE NOTE 1		
FINISH SEE NOTE 3		
APPLICATION		
DO NOT SCALE DRAWING		

30 Commerce Park Drive
 Niskayuna, NY, 12309, USA
 PH. (518) 377-2349, FAX (518) 344-7495

FORCE

TITLE: TCS 300W (3p) Boiler ASSY

SIZE DWG. NO. REV
C 53001_SM --

SCALE: 1:48 WEIGHT: 23255.30 SHEET 1 OF 1

4

3

2

1